Apex Solar Energy Technology (Yangzhou) Co., Ltd

Crystalline silicon PV modules Installation manual (IEC version)

In Australia installations should be in accordance to
AS/NZS 3000 and AS/NZS 5033.

2021-06-07 publish

2021-06-07 implement

Contents

Foreword	1
1 Scope	1
2 Disclaimer of Liability	1
3 Safety precautions	2
3.1 General safety	2
3.1 Electrical properties safety	2
3.3 Handling safety	3
3.4 Installation safety	3
4 Module specifications	4
4.1 Electrical characteristics	4
4.2 Product identification	4
4.3 Current sorting	4
5 Installation Conditions	4
5.1 Operating environment	4
5.2 Installation location	5
5.3 Tilt angle selection	5
6 Installation instructions	6
6.1 Conventional requirement	6
6.2 Two kinds of Mounting	6
6.2.1 Roof mounting	6
6.2.2 Ground mounting	7
6.3 Two installation methods	7
6.3.1 General rules	7
6.3.2 Clamp fasten the module	7
7 Electrical installations	9
7.1 General with regard to electrical installation	9
7.2 Cables and wiring	9
7.3 Connectors	10
7.4 Bypass diodes	10
7.5 Grounding	10
8 Maintenance	11
8.1 Usual maintenance	11
8.2 Visual inspection of modules	12
8.3 Check cables and connectors	12
8.4 Electrical ratings for all models	13
8.5 Electrical parameters at nmot	12
8.6 Low irradiance electrical parameters	12

Crystalline Silicon Module Products Installation Manual (IEC)

1 Scope

This manual contains information regarding the installation and safe handling of the photovoltaic module

(hereafter is referred to as "module") produced Yangzhou Apex Solar Energy Technology (Yangzhou) Co., Ltd

- (hereinafter referred to as " Apex ").
- This manual does not have any warranty significance,Expressed or implied. Installers must read and understand the manual before installation. The installer should conform to all safety precautions in the manual and local laws & regulations when installing module; before installing a solar photovoltaic system, installers should be familiar with the mechanical and electrical requirements for such a system.
- Keep this manual in a safe place for future reference (care and maintenance) and in case of sale or disposal of the modules.
- Any questions, please contact with the salesman or customer service personnel of Victor Solar for further explanations.
- This manual is applicable to the following products shown in table 1.

Table1 Product model code

Type	Product model
Mono	HRAP-144H-xxxM6(xxx=440-460, in step of 5); HRAP-120H-xxxM6(xxx=365-380, in step of 5); HRAP-156H-xxxM10(xxx=570-590, in step of 5); HRAP-144H-xxxM10(xxx=525-550, in step of 5); HRAP-132H-xxxM10(xxx=480-505, in step of 5); HRAP-120H-xxxM10(xxx=435-455, in step of 5); HRAP-108H-xxxM10(xxx=400-420, in step of 5); HRAP-132H-xxxM12(xxx=655-675, in step of 5); HRAP-120H-xxxM12(xxx=590-610, in step of 5); HRAP-110H-xxxM12(xxx=540-560, in step of 5). HRAP-144HBD-xxxM6 (xxx=435-455, in step of 5); HRAP-144HBD-xxxM10 (xxx=525-545, in step of 5); HRAP-132HBD-xxxM12 (xxx=640-655, in step of 5).

2 Disclaimer of Liability

2.1 Because using of this manual and the conditions or methods of the module installation, handling, use and maintenance are beyond the control range of Apex Solar, so If the conditions or methods of the module

installation, handling, use and maintenance of the customer are beyond the range specified in this manual and cause damage, Apex Solar does not assume responsibility for any loss, damage or expense thus caused.

2.2 Apex Solar has the right to refuse to compensate for the product damage due to construction or design defects of the solar photovoltaic system.

2.3 No responsibility is assumed by Apex Solar for any infringement of patent right or other rights of third parties, which may result from the customer's use of the Apex Solar's modules. No patent license or patent rights is granted to customer, express or implied, due to its use of Apex Solar's modules.

2.4 Failure to comply with the requirements listed in this manual will invalidate the "Limited Warranty for PV Modules" provided by salesman of Apex Solar. Meanwhile, recommendations provided in this manual are in order to improve the security of installation.

2.5 The information in this manual is based on Apex 's best knowledge and experience and is believed to be reliable; but such information including product specification (without limitations) and suggestions do not give any guarantee, Expressed or implied.

2.6 Apex Solar reserves the right to make changes to the product specifications or installation manual without prior notice.

3 Safety precautions

3.1 General safety

3.1.1 Apex Solar's modules have been evaluated by according to IEC61215 and IEC61730,application class A, modules rated for use in this application class may be used in system operating at greater than 50V DC or 240W.

3.1.2 The installer should abide by the relevant local laws and regulations when installing module. It is need to obtain the required certificates in advance when necessary, such as the building permit, please don't work under no protective measures.

3.1.3 Installing solar photovoltaic systems require specialized skills and knowledge. Installation should be performed only by qualified person. Installers should assume the risk of all injuries that might occur during installation, such as electric shock.

3.1.4 Photovoltaic modules are designed for outdoor use. Modules may be mounted on ground, rooftops, vehicles or boats. Proper design of support structures is the responsibility of the system designers or installers. When modules are mounted on rooftops, fire-protection rating of the final structure should be considered, and also the later maintenance. The rooftops and support structure for PV system should only be certified by architectural experts or engineer, which have a formal complete structure analysis results.

3.1.5 For your safety, Do not install or handle the modules under wet or adverse environment, including but not limited to strong wind, gusty wind, frosted roof surfaces ,wet environment.

3.2 Electrical properties safety

3.2.1 When exposed to direct sunlight, one individual PV module may generate DC voltages greater than 30 volts, so it is extremely dangerous to contact the metal part of the wire, which may get a shock, burn and kill. And do not touch or lean on a working module.

3.2.2 In order to avoid arc and electric shock, please do not disconnect electrical connections under load, Keep all electrical connectors dry and clean, and ensure that they are in proper working condition. Never insert metal objects into the module connector.

3.2.3 Do not apply paint or adhesive to module surface.

3.2.4 Do not use mirrors or other magnifiers to focus sunlight on the modules. Do not expose the backside of

modules directly to sunlight for a long time.

3.2.5 Do not change the configuration of the bypass diodes, Do not disassemble the modules or remove any attached nameplates or components from the modules.

3.2.6 Do not contact with module surface when the module is wet unless to clean the modules, please following requirements mentioned in this manual when cleaning.

3.3 Handling safety

3.3.1 Store pallets in a ventilated, rain-proof and dry location until the modules are ready to be unpacked, Keep children and unauthorized person away from the modules while transporting or installing them. Improper transportation or placing may lead to glass breakage or power loss of the modules, resulting in the loss of the use value of modules.

3.3.2 Handle modules with care, lift and put down modules gently. It is forbidden to carry or lift the modules by grabbing the junction box or cables. Carry a module by its edges with two or more persons.

3.3.3 To avoid module damage, do not place excessive loads on the module or twist the module frame. Do not stack the modules horizontally for transportation.

3.3.4 Pay more attention not to collide, scratch or press the module backside when transporting or installing.

3.3.5 To avoid module damage, do not stand or step on the module. Do not drop or place objects on the modules, Do not put tools on the module, Do not put the module on any hard surface, which maybe cause the cells broken.

3.3.6 Inappropriate transportation may damage the module. Control the vehicle speed when the road condition is relatively poor.

3.4 Installation safety

3.4.1 Abide by the safety regulations for all other components used in the PV system, including wiring and cables, connectors, controllers, inverters, storage batteries, etc., and use suitable equipment, connectors, wiring and mounting system for a PV system. It is better to use the same type modules in one system.

3.4.2 Do not install or handle the modules when they are wet or during strong wind. Keep the junction box's cover closed.

3.4.3 The front side of modules is constructed with tempered glass, which shall be handled with care. Improper operations may cause the tempered glass breakage. If the front glass is broken or if the back sheet is damaged, contact with any module surface or the aluminum frame can cause electrical shock, particularly when the module is wet. Broken or damaged modules must be disposed properly by professional.

3.4.4 When exposed to direct sunlight, one individual solar module may generate DC voltages greater than 30 volts. It is extremely dangerous to contact it.

3.4.5 Completely cover the module with an opaque material during installation to prevent electricity generation. Do not wear metallic rings, watchbands, ear, nose, lip rings or other metallic devices while installing or repairing photovoltaic systems. Use insulated tools that are approved for working on electrical installations and always keep them dry.

3.4.6 The triangle hole punched on the backside frame of the module is the drainage hole which cannot be blocked.

3.4.7 The maximum system voltage indicated in the rating label is 1500 V. Attention: During the system Installation, the maximum open circuit voltage in series cannot exceed the maximum system voltage.

3.4.8 During modules interconnection, ensure to fix the connecting cables to supporting bracket, so as to restrict the swing amplitude of the slack part of the cables.

- 3.4.9** Abide by the allowable minimum bending radius of the cables (suggest no less than 43mm).
- 3.4.10** Always protect the cable with conduit where animals or children can touch it.
- 3.4.11** Please use the connector which is specially designed for photovoltaic system, and assemble it with the tools recommended or specified by the manufacturer. In case that the connector applicable to the solar photovoltaic system is required, please contact the local supplier. Ban different connectors to plug each other.
- 3.4.12** Make sure that the polarity is correct when connecting the module with inverter, storage battery or combiner box to avoid the damage of bypass diodes in the modules due to incorrect polarity.
- 3.4.13** Do not drill holes in the frame, this may reduce the mechanical load ability and cause corrosion of the frame.
- 3.4.14** Do not scratch the anodized coating of the frame (except for grounding connection), this may cause corrosion of the frame or reduce the mechanical load ability.

4 Module specifications

4.1 Electrical characteristics

- 4.1.1** The deviation of electric characteristics between the measured value and nominal value is within $\pm 3\%$ (the electric characteristics including I_{sc} , V_{oc} and P_{max} tested Under Standard Test Conditions $1000W/m^2$, AM1.5 and $25^{\circ}C$ ($77^{\circ}F$)).
- 4.1.2** The rated fuse current value of the PV module is 30A.
- 4.1.3** Open circuit voltage t Victorerature coefficient: $-0.32\% / ^{\circ} C$.
- 4.1.4** Short circuit current t Victorerature coefficient: $0.05\% / ^{\circ} C$.
- 4.1.5** Maximum power t Victorerature coefficient: $-0.42\% / ^{\circ} C$.
- 4.1.6** Safety class: Class II
- 4.1.7** The maximum nominal voltage for all module series is 1500V according to IEC standards.

4.2 Product identification

Each module has labels providing the following information:

- 4.2.1** Rating label Describes the product type, rated power, rated current, rated voltage, open circuit voltage, short circuit current, all are measured at STC; weight, dimension, maximum system voltage and the fuse rating are all shown on the rating label.
- 4.2.2** Barcode Each module has a unique serial number. It contains the relevant production information of the module.

4.3 Current sorting

- 4.3.1** Modules are sorted by P_{max} firstly, then sorted by I_{mpp} (current at maximum power point) in the same P_{max} . Different color labels with distinct alphabetical letters are use to represent the I_{mpp} class.
- 4.3.2** Apex Solar recommends connecting the same I_{mpp} class modules in series in order to avoid or minimize power loss due to mismatch effects in arrays.

5 Installation Conditions

5.1 Operating environment

Apex Solar's PV module should operate in the following environmental conditions:

5.1.1 Ambient temperature:-20°C to +40°C

5.1.2 Operating temperature of the module:-40°C to +70°C

5.1.3 Humidity:85%RH

5.1.4 Designed mechanical load and safety factor:

Positive:3600Pa(1.5 times safety factor).

Negative:1600Pa(1.5 times safety factor).

Notes: Professional system installers are responsible for mechanical load calculations when Design photovoltaic systems.

5.2 Installation location

5.2.1 In most applications, PV modules should be installed in a location where they will receive maximum sunlight throughout the year. In the northern hemisphere, modules should typically face south, and in the southern hemisphere, modules should typically face north.

5.2.2 The module shall be installed in the place where the sunshine is adequate. the module surface shall not be partly shaded by trees, building, clothes, tools, packaging materials, etc. because these objects will form shadow in the module surface leading to loss of system output power.

5.2.3 The module shall be installed in the well-ventilated place; meanwhile, enough space for airiness shall be sated at the back and sides of the module, so that the heat generated during operation can be radiated in time.

5.2.4 Modules must not be installed nor operated in locations with serious salt mist, hail, snow cover, sandstorm, smoke dust, air pollution, acid rain, soot, etc. and harsh environment. We suggest that the module shall be installed in dry areas with the moderate climate.

5.2.5 Never place the module near a naked flame or inflammable gas. Apex Solar's modules must be installed on suitable buildings with appropriate mounting structures, or other place suitable for modules installation, such as ground, carports, building facades, rooftops, PV trackers.

5.2.6 Lighting protection is necessary for PV systems in this area with high probability of lightning strikes.

5.2.7 Do not install the modules in this location with water immersion or near the sprinkler.

5.2.8 Modules must not be sited in locations with strong corrosive substances, such as salt, salt mist or other type of corrosive agent, which could affect the safety and/or performance of the modules. In case of the special installation environments such as the seaside, farm, high humidity environment and sandstorm environment, please contact the local dealer for professional support and confirmation.

5.2.9 The installation of PV modules should not exceed 2000 meters above sea level.

5.3 Tilt angle selection

5.3.1 The tilt angle of the Modules is measured between the surface of the modules and a horizontal ground surface, the modules generates maximum power output when it faces the sun directly.

5.3.2 Modules connected in series should be at the same tilt and azimuth. Differing tilt or azimuth may cause mismatch of power output due to differing amount of sunlight exposure for each module and reduce the efficiency of the PV system.

5.3.3 Do consider the power output in winter when choosing the optimal tilt angle for the module, which will lead to enough power output throughout the year.

5.3.4 For detailed information on the best installation angle, please refer to standard solar photovoltaic Installation guides or consults a reputable solar installer or systems integrator.

6 Installation instructions

6.1 Conventional requirement

6.1.1 Ensure that the installed modules and supporting rail of modules are strong enough, the entire PV system consisting of modules must be able to withstand anticipated mechanical pressure. The installer must provide the guarantee. The installation supporting rail must be tested by the third-party organization with the analysis ability of Static Mechanical according to the local national or international standards.

6.1.2 The supporting rail must be made of environmental corrosion, anti-rust and UV-resistant materials.

6.1.3 Modules must be securely fastened to the supporting rail.

6.1.4 Drilling holes on the surface of module glass or drilling additional mounting holes on module frames may void the warranty.

6.1.5 Forces generated during thermal expansion and contraction of the supporting rail may influence the performance and use of the module, so make ensure that the minimum distance between two neighboring frames is 10mm, but in order to ensure good ventilation. Suggest this distance between two neighboring frames is 30mm.

6.1.6 Dust gathering on the surface of module will reduce the power output, so solar system installer should calculate the optimal tilt of the module to make it easier for dust to be washed off by rain.

6.1.7 The bearing surface of the supporting system must be smooth without any twist or deformation, and all of them shall be at the same height without dislocation.

6.2 Two kinds of mounting

6.2.1 Roof mounting

6.2.1.1 It is necessary to provide a special supporting rail for the roof mounting. When installing a module on a roof or building, ensure that it is securely fastened and cannot fall or be damaged as a result of strong winds or heavy snow. During roof mounting, check the building codes being used to ensure that the building and its structure where the module is installed have adequate bearing and sealing capacity. The roof when penetrated during module installation shall be properly sealed to avoid rainwater leakage.

6.2.1.2 To be suitable for operation, reduce steam condensation and facilitate the ventilation & heat dissipation of the module during tile installation, the module shall be parallel to the wall or roof surface of the building, and the distance between module and surface of the wall or roof shall be at least 115mm to prevent wiring damage and to allow air circulation, ventilation and heat dissipation behind the module. For stacking type installation, the module shall be installed on the fire-resistant roof. The Fire Resistance Rated Class of the modules is Class C, and the modules are suitable for mounting on an above Class C roof. Do not install modules on a roof or building during strong wind.

6.2.1.3 For the roof system installed in the area with relatively heavy snowfall or snow cover in the meteorological records, the installer shall reinforce the supporting system at the lower frame of the module, in order to prevent the lower frame from being pressed and damaged by the falling snow or freezing of the melt ed snow. TW solar suggests selecting the support reinforcing mechanism shown in Figure1.

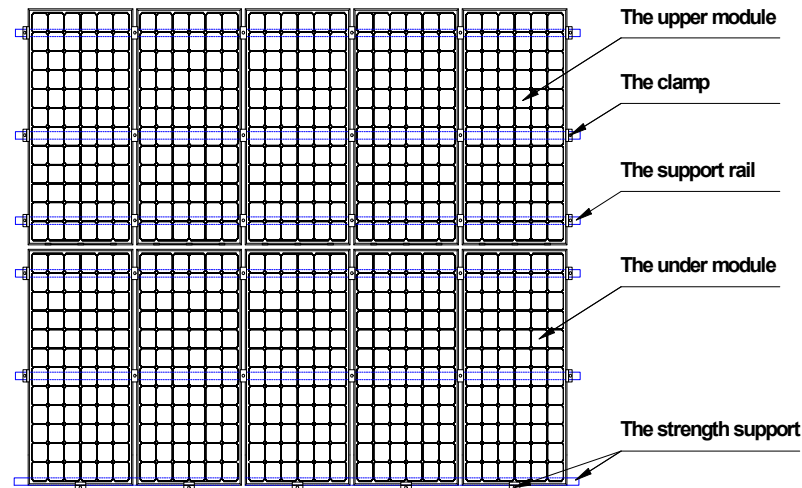

FIG 1 Schematic diagram of reinforcement mounting of module

6.2.2 Ground mounting

Select the height of the mounting system to prevent the lowest edge of the module from being covered by snow for a long time in winter in areas with heavy snowfalls. The module shall be installed on the supporting rail with appropriate height instead of being directly laid on the ground. In addition, the lowest portion of the module shall be high enough (≥ 900 mm) from ground, so that it is not shaded by plants and trees, or damaged by sand and stone driven by wind, or not shaded by the mud splashed by rain water.

6.3 Two installation methods

6.3.1 General rules

- a) Modules can be fastened on the supporting system using clamps. Modules must be installed according to the following methods or instructions. If not the warranty may be void.
- b) The modules have been passed the mechanical load test according to IEC standard. For standard installation, the four symmetry holes close to the inner side on module frames or clamps shall be used to fasten the module to the supporting rail. Victor solar's modules can sustain 2400 Pa wind pressure and 5400 Pa snow load. System designer and installer are responsible for load calculations.
- c) The supporting rail and other materials required (such as screw) shall be made of durable, resistance to environmental corrosion, anti-rust and UV-resistant materials.

6.3.2 Clamp fasten the module

6.3.2.1 Using suitable number of clamps to fasten the module to the supporting rail, Apex Solar suggest installer clamp the module by the long side of the module frame, and the area of module frame fastened by each clamp shall be no less than 800 mm^2 . (clamp length ≥ 80 mm, the clamped width of module frame shall be in this area: 9-11mm).

6.3.2.2 Do not contact the front glass, and do not scratch or deform the module frame in any way when fastening the module. Avoid shading effects from the clamps. Drainage holes on the modules frame must not be plugged.

6.3.2.3 Using at least four clamps to fasten each module, two clamps should be fastened on each long side of the module. According to local Environment (depending on wind power and snow loads), additional clamps may be

required to ensure modules and PV system to withstand anticipated mechanical pressure. We recommends using the following clamps (as shown in Figure 2) ,or approved by reputable solar installer or systems integrator.

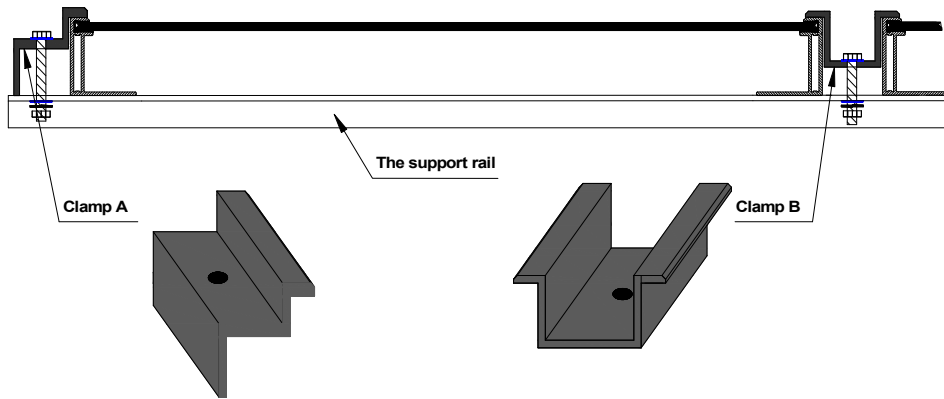

Clamp A: Fasten the Fringe modules

Clamp B: Fasten the Middle modules

FIG 2 Schematic diagram of module fastened by clamp method

6.3.2.4 The modules should be fastened to the supporting rail using anti-corrosion clamps, screws, spring washers and flat washers. And the clamps should always be mounted in a symmetric position respect to the center. Apex solar suggested selecting M8 screw together with matched nut. Recommended torque should be 8 Newton-meters.

6.3.2.5 If heavy snowfall, snow cover or large wind pressure exist in the module installation area, Apex solar suggests the installers to selecting the clamping methods of 5400Pa mechanical loading to clamp the module (as shown in Table 3) to improve the bearing capacity for snow load at front side and wind pressure at back side, and enhance the system capacity.

Table2 Range of clamp to fasten the module

Module type	Mechanical Loading/Pa	A/mm	B/mm	C/mm	D/mm	E/mm	F/mm
	2400			330±50	330±50	9~11	≥80
	5400					9~11	≥80
	2400			330±50	330±50	9~11	≥80
	5400					9~11	≥80

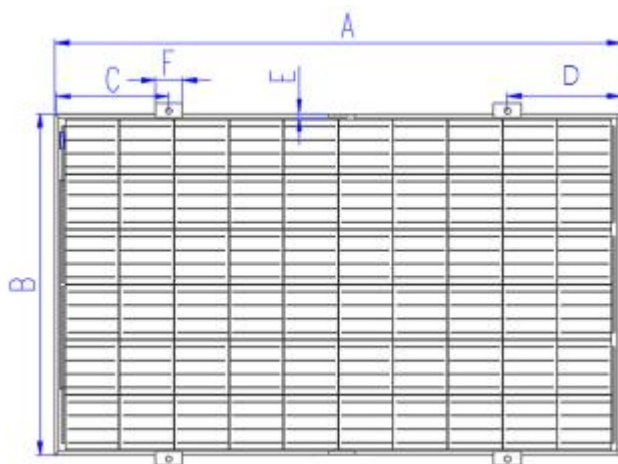

Note:

- A: Length of this type of module.
- B: Width of this type of module.
- C: The distance of clamp center1 from the edge of this type of module.
- D: The distance of clamp center 2 from the edge of this type of module.
- E: Clamped width of the module frame by the clamp of this type of module.
- F: Clamped length of the module frame by the clamp of this type of module.

*** Notes:** Apex solar's limited warranty will be void in cases where improper clamps or installation methods deviating from this manual are used. When using clamps to fasten the modules, pay attention to the following requirements:

- (a) Take care of the module frames, not to twist or deform them.
- (b) Avoid the clamps' shading influence the module.
- (c) Not to damage the surface of module frame.
- (d) Make sure that the module's drainage holes not be plugged.

6.3.2.6 For matters concerning clamp or installation not mentioned in this manual, contact the local dealer for professional support.

7 Electrical installations

7.1 General with regard to electrical installation

7.1.1 Under normal outdoor conditions, a module is likely to produce different current and voltage than the values measured under STC in the specification of Apex solar's module. Therefore, when determining the parameters (for example, nominal voltage, conductor capacity, fuse capacity and controller capacity, etc.) related to the power output of the PV system, the values of short-circuit current and open circuit voltage of the modules should be multiplied by a factor of 125% during design and installation.

7.1.2 Try to use the modules with the same configuration in the same PV system. If the modules are connected in series, the total voltage is the sum of voltages of all the modules. The maximum voltage of string does not exceed the maximum system voltage of the modules (the maximum system voltage of Apex solar modules is 1500V), the maximum number of modules that can be connected in a series string must be calculated in accordance with applicable regulations, make sure the open circuit voltage of string does not exceed the maximum system voltage of the modules and the other electrical DC components required at the minimum temperature at the PV system location. Using the following formula:

$$\text{System voltage} = N * V_{oc} * [1 + \lambda_{V_{oc}} (T_{min} - 25^{\circ}\text{C})]$$

N — number of modules in series

V_{oc} — open circuit voltage at STC (refer to product label or data sheet)

λ_{V_{oc}} — Thermal coefficient of V_{oc} of each module (refer to product data sheet)

T_{min} — minimum ambient temperature at the PV system location

7.1.3 If the PV system requires the installation of high current, several PV modules can be connected in parallel, and total current is the sum of current of all the modules. The maximum parallel number of the modules $N = I_{max} (\text{fuse rating}) / I_{sc}$,

7.1.4 An over-current protection device with appropriately rated must be used when reverse current could exceed the value of the maximum fuse rating of the module, an over-current protection devices is required for each series string if more than two series strings are connected in parallel.

7.1.5 When installing the module, place the end with the junction box up and try to avoid the rain.

7.1.6 Do not carry out installation in rainy weather, because humidity will void the insulation protection, Thus cause safety accidents.

7.2 Cables and wiring

7.2.1 The junction boxes with IP67 protection class have been designed to be easily interconnected in series by

the connectors. Each module has two single-conductor wires, one positive and one negative, which are pre-wired inside the junction box. Installers can connect two modules by firmly inserting the positive connector of a module into the negative connector of the other module.

7.2.2 Never perform pretreatment to modules including connector, junction box and cable with lubricating oil or cleaning agent made of alkanet materials during installation.

7.2.3 The cross section area of the cable and connector capacity selected must satisfy the maximum short-circuit current of the system (It is recommended that the cross section area of the cable used for the single module is 4mm^2 , Please note that the tVictorerature limit range of the cable is $-40^{\circ}\text{C}\sim+85^{\circ}\text{C}$).

7.2.4 When fastening the cables to the supporting rail, pay attention to avoid mechanical damage to the cables or modules, and also making a special design to protect the cables from environmental corrosion and direct sunshine, for example, put the cable into the supporting beam or special pipes with UV-resistant materials.

7.2.5 The cables designed are sunlight resistant and waterproof, but also to avoid direct sunlight exposure and water immersion of the cables

7.3 Connectors

7.3.1 When connecting modules, make sure that the connectors of the same series module shall come from the same manufacturer or totally be compatible with each others, and the same requirements shall go to the connection terminals of series string and PV system, because the connectors from different manufacturers may not be compatible with each others, which easily leads to mismatch risk.

7.3.2 Ensure that connector caps are tightened before connecting the modules, keep connectors dry and clean. Do not attVictort to make an electrical connection when the connectors are wet, soiled, or otherwise faulty conditions. Avoid sunlight exposure and water immersion of the connectors.

7.3.3 The connector should be mated with its original female or male connector of the same supplier.

7.4 Bypass diodes

The junction boxes of Apex Solar's modules contain bypass diodes wired in parallel with the PV cell strings. In case of partial cell shading or damaged, the parallel diodes will bypass the current generated by the non-shaded cells, thereby limiting modules heating and performance losses. Take care, the bypass diodes are not over-current protection devices.

7.5 Grounding

7.5.1 Apex Solar modules use anti-corrosion and oxidation resistance aluminum frame as rigid supporting. In order to protect the module from lightning strike, electrostatic damage, and personnel safety, all module frames and mounting racks must be properly grounded, as shown in Figure 3: grounding hole and grounding label. Use the recommended connector terminal, or an equivalent, to connect the cable to the frame, and assure good electrical contact as shown in Figure 5: Grounding method.

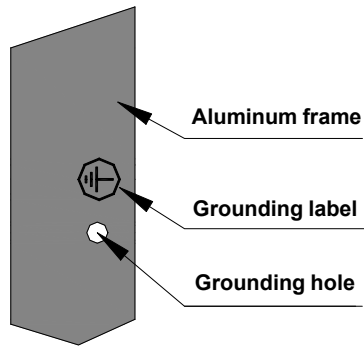

FIG 3 Grounding hole and ground label

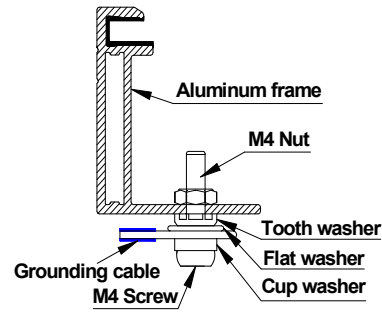

FIG 4 Grounding method

7.5.2 The frames have pre-drilled grounding holes and brand with signs, these holes should be only used for grounding purposes, but not for mounting the modules. And do not drill any additional grounding holes on the frames of the module, which may void the warranty.

7.5.3 If the supporting system is made of metal, the surface must be electroplated and have excellent conductivity.

7.5.4 The grounding cables must be fully contact with inside of the aluminum alloy, and the connection terminal must penetrate the oxidation coating of frame during grounding. Connecting the module frames and supporting beams using suitable grounding conductors can achieve good grounding.

7.5.5 The grounding cables must be connected to the earth through a suitable grounding electrode. Recommend to use the grounding accessories (lugs) to connect the cables. Welding grounding cable to the jack of lugs, then inserting M4 screws into the ring of the lugs and the grounding holes of module frames, fastening with M4 nuts. Spring washers should be used to prevent the screws from loosening and lead to poor grounding.

7.5.6 If the module is used in high-temperature and high-humidity environment, Apex solar suggest the customer configure the inverter which allows negative grounding and contains isolation transformer (as shown in FIG5).

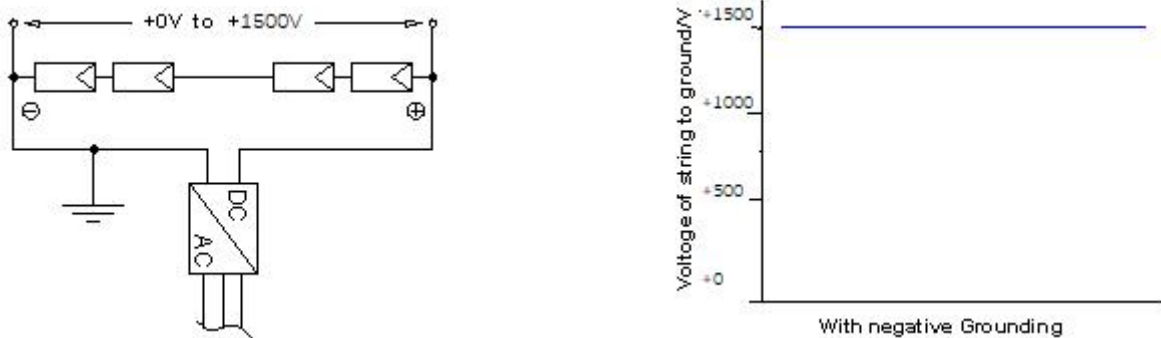

FIG 5 Schematic diagram for grounding potential of the inverter

8 Maintenance

8.1 Usual maintenance

8.1.1 In the warranty period, the user must carry out regular inspection and maintenance using, which is the user's responsibility. And the user must inform the supplier within one week when founding the damages of modules.

8.1.2 When modules are working. There should not be environmental influence factors to cover shadows in the modules, such as other modules, supporting rail, plants, large number of dust etc., which may directly reduce the power output and may even cause regional hot-spot effect. Therefore clean the glass surface on a regular basis, clean modules take measures so as:

- (a) In general, normal rainfall can keep the glass surface clean, if the dirt accumulated too much, using water and a soft sponge or cloth for cleaning. If necessary, a mild, non-abrasive cleaning agent can be used to remove stubborn dirt.
- (b) Avoid pressing part of the module hard during cleaning, which may cause glass deformation, cell damage and reduction of the module's life.
- (c) Remove the snow covered on the module in time to avoid the module damage caused by long-term accumulation of snow cover and freezing of melted snow.
- (d) Do not clean module with cold water when the module temperature is highest in the daytime, and the thermal shocks might damage the module.
- (e) when cleaning the back of the module needs to avoid piercing back-sheet, module needs to be often cleaned for horizontal installation (the cleaning frequency depends on the degree of dirt) .

8.2 Visual inspection of modules

Inspect the modules visually to find whether there are appearance defects, the following need special attention:

- (a) Check whether the module glass is broken ;
- (b) Check whether there is burning vestige or back up on the back-sheet;
- (c) Check whether there is corrosion along the cell bus-bar or damaged of encapsulation materials or a large area of the bubbles etc;
- (d) Check aluminum frame holes are normal; the screws of installation are tightness and electrical cables are situation.

8.3 Check cables and connectors

8.3.1 Carry out regular inspection of mechanics and electric, ensure the cleaning of the connector and be reliable connected.

8.3.2 Check whether all electrical connections are tight or corrosion free.

8.3.3 Maintenance should be carried out at least once a year.

8.3.4 Completely cover the module with an opaque material during repairing the module to prevent electric shock. When exposed to direct sunlight, one individual PV module may generate high DC voltages, so please be cautious of repairing. And repairing modules must be disposed properly by professional.

Note 1: If any problem arises, have it consulted by a competent specialist.

Note 2: If the maintenance measures are not included in this manual, please contact the local dealer for professional support.

Note 3: Connector :Supplier: Suzhou XTONG photovoltaic technologies Co., Ltd.Model:PV-XT101.1 .

Supplier: Ningbo Huayu Photovoltaic Technology Co. , Ltd.Model:PV-H4

Bypass diode :Supplier: Suzhou XTONG photovoltaic technologies Co., Ltd .Model:XT3050M -B

Supplier: Ningbo Huayu Photovoltaic Technology Co. , Ltd.Model:HY5050MK

Note 4: the connector should be mated with its original female or male connector of the same supplier

8.4 Electrical ratings for all models

Model Name	Weight [KG]	Dimensions [length x width x height]	Pmax (with tolerance) [W]	System voltage [V]	Voc (with tolerance) [V]	Isc (with tolerance) [A]	VPmax [V]	IPmax [A]
HRAP-120H-365M6	19.5	1755x 1038 x 35	365 ± 3%	1500	41.05 ± 3%	11.27 ± 3%	33.85	10.79
HRAP-120H-370M6	19.5	1755x 1038 x 35	370 ± 3%	1500	41.25 ± 3%	11.35 ± 3%	34.05	10.87
HRAP-120H-375M6	19.5	1755x 1038 x 35	375 ± 3%	1500	41.45 ± 3%	11.43 ± 3%	34.25	10.95
HRAP-144H-435M6	23.5	2094x 1038 x 35	435 ± 3%	1500	49.30 ± 3%	11.26 ± 3%	40.75	10.68
HRAP-144H-440M6	23.5	2094x 1038 x 35	440 ± 3%	1500	49.50 ± 3%	11.33 ± 3%	40.95	10.74
HRAP-144H-445M6	23.5	2094x 1038 x 35	445 ± 3%	1500	49.70 ± 3%	11.40 ± 3%	41.15	10.82
HRAP-144H-450M6	23.5	2094x 1038 x 35	450 ± 3%	1500	49.90 ± 3%	11.47 ± 3%	41.35	10.89
HRAP-144H-455M6	23.5	2094x 1038 x 35	455 ± 3%	1500	50.10 ± 3%	11.54 ± 3%	41.55	10.96
HRAP-144H-460M6	23.5	2094x 1038 x 35	460 ± 3%	1500	50.30 ± 3%	11.61 ± 3%	41.75	11.03
HRAP-108H-400M10	21.5	1724x 1134 x 30	400 ± 3%	1500	36.75 ± 3%	13.76 ± 3%	30.75	13.01
HRAP-108H-405M10	21.5	1724x 1134 x 30	405 ± 3%	1500	37.00 ± 3%	13.83 ± 3%	31.00	13.07
HRAP-108H-410M10	21.5	1724x 1134 x 30	410 ± 3%	1500	37.25 ± 3%	13.88 ± 3%	31.25	13.12
HRAP-120H-435M10	25	1909x 1134 x 35	435 ± 3%	1500	40.80 ± 3%	13.34 ± 3%	33.76	12.89
HRAP-120H-440M10	25	1909x 1134 x 35	440 ± 3%	1500	40.95 ± 3%	13.41 ± 3%	33.91	12.98
HRAP-120H-445M10	25	1909x 1134 x 35	445 ± 3%	1500	41.10 ± 3%	13.52 ± 3%	34.06	13.07
HRAP-120H-450M10	25	1909x 1134 x 35	450 ± 3%	1500	41.25 ± 3%	13.62 ± 3%	34.21	13.16
HRAP-120H-455M10	25	1909x 1134 x 35	455 ± 3%	1500	41.40 ± 3%	13.72 ± 3%	34.36	13.25
HRAP-132H-480M10	26.3	2094x 1134 x 35	480 ± 3%	1500	45.07 ± 3%	13.65 ± 3%	37.62	12.76
HRAP-132H-485M10	26.3	2094x 1134 x 35	485 ± 3%	1500	45.20 ± 3%	13.72 ± 3%	37.81	12.83
HRAP-132H-490M10	26.3	2094x 1134 x 35	490 ± 3%	1500	45.33 ± 3%	13.79 ± 3%	37.99	12.90
HRAP-132H-495M10	26.3	2094x 1134 x 35	495 ± 3%	1500	45.46 ± 3%	13.86 ± 3%	38.17	12.97
HRAP-132H-500M10	26.3	2094x 1134 x 35	500 ± 3%	1500	45.59 ± 3%	13.93 ± 3%	38.35	13.04
HRAP-132H-505M10	26.3	2094x 1134 x 35	505 ± 3%	1500	45.72 ± 3%	14.00 ± 3%	38.53	13.11
HRAP-144H-525M10	29	2279x 1134 x 35	525 ± 3%	1500	49.15 ± 3%	13.65 ± 3%	41.15	12.76
HRAP-144H-530M10	29	2279x 1134 x 35	530 ± 3%	1500	49.30 ± 3%	13.72 ± 3%	41.31	12.83
HRAP-144H-535M10	29	2279x 1134 x 35	535 ± 3%	1500	49.45 ± 3%	13.79 ± 3%	41.47	12.90
HRAP-144H-540M10	29	2279x 1134 x 35	540 ± 3%	1500	49.60 ± 3%	13.86 ± 3%	41.64	12.97
HRAP-144H-545M10	29	2279x 1134 x 35	545 ± 3%	1500	49.75 ± 3%	13.93 ± 3%	41.80	13.04
HRAP-144H-550M10	29	2279x 1134 x 35	550 ± 3%	1500	49.90 ± 3%	14.00 ± 3%	41.96	13.11
HRAP-156H-570M10	31	2474x 1134 x 35	570 ± 3%	1500	53.22 ± 2%	13.40 ± 3%	44.02	12.96
HRAP-156H-575M10	31	2474x 1134 x 35	575 ± 3%	1500	53.37 ± 3%	13.48 ± 3%	44.17	13.03
HRAP-156H-580M10	31	2474x 1134 x 35	580 ± 3%	1500	53.52 ± 3%	13.56 ± 3%	44.32	13.10
HRAP-156H-585M10	31	2474x 1134 x 35	585 ± 3%	1500	53.67 ± 3%	13.64 ± 3%	44.47	13.17

HRAP-156H-590M10	31	2474x 1134 x 35	590 ± 3%	1500	53.82 ± 3%	13.72 ± 3%	44.62	13.23
HRAP-120E-390M12	21.3	1761x 1098 x 35	390 ± 3%	1500	40.80 ± 3%	12.14 ± 3%	33.80	11.54
HRAP-120E-395M12	21.3	1761x 1098 x 35	395 ± 3%	1500	41.00 ± 3%	12.21 ± 3%	34.00	11.62
HRAP-120E-400M12	21.3	1761x 1098 x 35	400 ± 3%	1500	41.20 ± 3%	12.28 ± 3%	34.20	11.70
HRAP-120E-405M12	21.3	1761x 1098 x 35	405 ± 3%	1500	41.40 ± 3%	12.34 ± 3%	34.40	11.77
HRAP-150E-480M12	26.3	2185x 1098 x 35	480 ± 3%	1500	50.80 ± 3%	11.99 ± 3%	42.00	11.42
HRAP-150E-485M12	26.3	2185x 1098 x 35	485 ± 3%	1500	51.10 ± 3%	12.07 ± 3%	42.20	11.49
HRAP-150E-490M12	26.3	2185x 1098 x 35	490 ± 3%	1500	51.30 ± 3%	12.14 ± 3%	42.40	11.56
HRAP-150E-495M12	26.3	2185x 1098 x 35	495 ± 3%	1500	51.50 ± 3%	12.21 ± 3%	42.60	11.63
HRAP-150E-500M12	26.3	2185x 1098 x 35	500 ± 3%	1500	51.70 ± 3%	12.28 ± 3%	42.80	11.69
HRAP-150E-505M12	26.3	2185x 1098 x 35	505 ± 3%	1500	51.90 ± 3%	12.35 ± 3%	43.00	11.75
HRAP-110H-530M12	28.6	2384x 1098 x 35	530 ± 3%	1500	37.10 ± 3%	18.31 ± 3%	30.80	17.21
HRAP-110H-535M12	28.6	2384x 1098 x 35	535 ± 3%	1500	37.30 ± 3%	18.36 ± 3%	31.00	17.28
HRAP-110H-540M12	28.6	2384x 1098 x 35	540 ± 3%	1500	37.50 ± 3%	18.41 ± 3%	31.20	17.33
HRAP-110H-545M12	28.6	2384x 1098 x 35	545 ± 3%	1500	37.70 ± 3%	18.47 ± 3%	31.40	17.37
HRAP-110H-550M12	28.6	2384x 1098 x 35	550 ± 3%	1500	37.90 ± 3%	18.52 ± 3%	31.60	17.40
HRAP-110H-555M12	28.6	2384x 1098 x 35	555 ± 3%	1500	38.10 ± 3%	18.56 ± 3%	31.80	17.45
HRAP-110H-560M12	28.6	2384x 1098 x 35	560 ± 3%	1500	38.30 ± 3%	18.60 ± 3%	32.00	17.50
HRAP-120H-585M12	30.9	2172x 1303 x 35	585 ± 3%	1500	40.90 ± 3%	18.37 ± 3%	33.80	17.31
HRAP-120H-590M12	30.9	2172x 1303 x 35	590 ± 3%	1500	41.10 ± 3%	18.42 ± 3%	34.00	17.35
HRAP-120H-595M12	30.9	2172x 1303 x 35	595 ± 3%	1500	41.30 ± 3%	18.47 ± 3%	34.20	17.40
HRAP-120H-600M12	30.9	2172x 1303 x 35	600 ± 3%	1500	41.50 ± 3%	18.52 ± 3%	34.40	17.44
HRAP-120H-605M12	30.9	2172x 1303 x 35	605 ± 3%	1500	41.70 ± 3%	18.57 ± 3%	34.60	17.49
HRAP-120H-610M12	30.9	2172x 1303 x 35	610 ± 3%	1500	41.90 ± 3%	18.62 ± 3%	34.80	17.54
HRAP-132H-640M12	34	2384x 1303 x 35	640 ± 3%	1500	44.89 ± 3%	18.33 ± 3%	36.99	17.31
HRAP-132H-645M12	34	2384x 1303 x 35	645 ± 3%	1500	45.09 ± 3%	18.37 ± 3%	37.19	17.35
HRAP-132H-650M12	34	2384x 1303 x 35	650 ± 3%	1500	45.29 ± 3%	18.43 ± 3%	37.39	17.39
HRAP-132H-655M12	34	2384x 1303 x 35	655 ± 3%	1500	45.29 ± 3%	18.49 ± 3%	37.59	17.43
HRAP-132H-660M12	34	2384x 1303 x 35	660 ± 3%	1500	45.69 ± 3%	18.52 ± 3%	37.79	17.47
HRAP-132H-670M12	34	2384x 1303 x 35	665 ± 3%	1500	45.89 ± 3%	18.55 ± 3%	37.99	17.77
HRAP-132H-675M12	34	2384x 1303 x 35	670 ± 3%	1500	46.09 ± 3%	18.58 ± 3%	38.09	18.07

8.5 Electrical parameters at nmot

Model Name	Weight [KG]	Dimensions [length x width x height]	Pmax (with tolerance) [W]	System voltage [V]	Voc (with tolerance) [V]	Isc (with tolerance) [A]	VPmax [V]	IPmax [A]
HRAP-120H-365M6	19.5	1755x 1038 x 35	266.7	1500	38.1	9.06	31.2	8.56

HRAP-120H-370M6	19.5	1755x 1038 x 35	270.4	1500	38.3	9.12	31.3	8.63
HRAP-120H-375M6	19.5	1755x 1038 x 35	274.1	1500	38.5	9.19	31.5	8.7
HRAP-144H-435M6	23.5	2094x 1038 x 35	322.2	1500	46	9.12	37.7	8.54
HRAP-144H-440M6	23.5	2094x 1038 x 35	326	1500	46.2	9.17	37.9	8.6
HRAP-144H-445M6	23.5	2094x 1038 x 35	329.7	1500	46.3	9.23	38.1	8.66
HRAP-144H-450M6	23.5	2094x 1038 x 35	333.4	1500	46.5	9.29	38.3	8.71
HRAP-144H-455M6	23.5	2094x 1038 x 35	337.1	1500	46.7	9.35	38.5	8.76
HRAP-144H-460M6	23.5	2094x 1038 x 35	340.8	1500	46.9	9.40	38.7	8.81
HRAP-108H-400M10	21.5	1724x 1134 x 30	299	1500	34.55	11.13	28.56	10.47
HRAP-108H-405M10	21.5	1724x 1134 x 30	302.7	1500	34.79	11.18	28.80	10.52
HRAP-108H-410M10	21.5	1724x 1134 x 30	306.5	1500	35.08	11.22	29.03	10.56
HRAP-120H-435M10	25	1909x 1134 x 35	326	1500	37.61	11.11	31.19	10.46
HRAP-120H-440M10	25	1909x 1134 x 35	330	1500	37.76	11.19	31.34	10.54
HRAP-120H-445M10	25	1909x 1134 x 35	334	1500	37.91	11.28	31.49	10.62
HRAP-120H-450M10	25	1909x 1134 x 35	338	1500	38.06	11.36	31.64	10.69
HRAP-120H-455M10	25	1909x 1134 x 35	342	1500	38.21	11.45	31.79	10.77
HRAP-132H-480M10	26.3	2094x 1134 x 35	363	1500	42.15	10.99	35.54	10.21
HRAP-132H-485M10	26.3	2094x 1134 x 35	367	1500	42.30	11.06	35.67	10.28
HRAP-132H-490M10	26.3	2094x 1134 x 35	370	1500	42.43	11.13	35.76	10.36
HRAP-132H-495M10	26.3	2094x 1134 x 35	374	1500	42.58	11.20	35.84	10.44
HRAP-132H-500M10	26.3	2094x 1134 x 35	378	1500	42.72	11.27	35.93	10.52
HRAP-132H-505M10	26.3	2094x 1134 x 35	382	1500	42.86	11.34	36.02	10.60
HRAP-144H-525M10	29	2279x 1134 x 35	397	1500	46.05	10.97	38.36	10.35
HRAP-144H-530M10	29	2279x 1134 x 35	401	1500	46.18	11.01	38.57	10.39
HRAP-144H-535M10	29	2279x 1134 x 35	405	1500	46.31	11.05	38.78	10.43
HRAP-144H-540M10	29	2279x 1134 x 35	408	1500	46.43	11.09	38.99	10.47
HRAP-144H-545M10	29	2279x 1134 x 35	412	1500	46.55	11.13	39.20	10.51
HRAP-144H-550M10	29	2279x 1134 x 35	416	1500	46.68	11.17	39.43	10.55
HRAP-156H-570M10	31	2474x 1134 x 35	426	1500	48.91	11.17	40.5	10.53
HRAP-156H-575M10	31	2474x 1134 x 35	430	1500	49.06	11.24	40.65	10.59
HRAP-156H-580M10	31	2474x 1134 x 35	434	1500	49.21	11.31	40.8	10.65
HRAP-156H-585M10	31	2474x 1134 x 35	438	1500	49.36	11.38	40.95	10.71
HRAP-156H-590M10	31	2474x 1134 x 35	442	1500	49.51	11.44	41.1	10.77
HRAP-120E-390M12	21.3	1761x 1098 x 35	295	1500	38.4	9.78	31.8	9.26
HRAP-120E-395M12	21.3	1761x 1098 x 35	298	1500	38.6	9.84	32	9.32
HRAP-120E-400M12	21.3	1761x 1098 x 35	302	1500	38.8	9.9	32.2	9.38
HRAP-120E-405M12	21.3	1761x 1098 x 35	306	1500	38.9	9.69	32.5	9.41

HRAP-150E-480M12	26.3	2185x 1098 x 35	363	1500	48	9.65	39.6	9.15
HRAP-150E-485M12	26.3	2185x 1098 x 35	367	1500	48.2	9.72	39.8	9.2
HRAP-150E-490M12	26.3	2185x 1098 x 35	371	1500	48.4	9.77	40.0	9.26
HRAP-150E-495M12	26.3	2185x 1098 x 35	375	1500	48.6	9.83	40.2	9.32
HRAP-150E-500M12	26.3	2185x 1098 x 35	379	1500	48.8	9.89	40.4	9.37
HRAP-150E-505M12	26.3	2185x 1098 x 35	382	1500	49	9.94	40.6	9.43
HRAP-110H-530M12	28.6	2384x 1098 x 35	401	1500	35	14.76	28.6	14.01
HRAP-110H-535M12	28.6	2384x 1098 x 35	405	1500	35.1	14.8	28.8	14.06
HRAP-110H-540M12	28.6	2384x 1098 x 35	409	1500	35.3	14.84	29	14.1
HRAP-110H-545M12	28.6	2384x 1098 x 35	413	1500	35.5	14.88	29.2	14.15
HRAP-110H-550M12	28.6	2384x 1098 x 35	417	1500	35.7	14.92	29.3	14.19
HRAP-110H-555M12	28.6	2384x 1098 x 35	420	1500	35.9	14.96	29.5	14.23
HRAP-110H-560M12	28.6	2384x 1098 x 35	423	1500	36.1	14.98	29.7	14.28
HRAP-120H-585M12	30.9	2172x 1303 x 35	443	1500	38.5	14.81	31.5	14.05
HRAP-120H-590M12	30.9	2172x 1303 x 35	447	1500	38.7	14.85	31.7	14.09
HRAP-120H-595M12	30.9	2172x 1303 x 35	451	1500	38.9	14.88	31.9	14.13
HRAP-120H-600M12	30.9	2172x 1303 x 35	454	1500	39.1	14.92	32	14.18
HRAP-120H-605M12	30.9	2172x 1303 x 35	458	1500	39.3	14.96	32.2	14.22
HRAP-120H-610M12	30.9	2172x 1303 x 35	462	1500	39.5	14.98	32.4	14.26
HRAP-132H-640M12	34	2384x 1303 x 35	485	1500	42.19	14.76	34.49	14.06
HRAP-132H-645M12	34	2384x 1303 x 35	488	1500	42.39	14.78	34.69	14.08
HRAP-132H-650M12	34	2384x 1303 x 35	492	1500	42.59	14.84	34.89	14.11
HRAP-132H-655M12	34	2384x 1303 x 35	496	1500	42.79	14.88	35.09	14.14
HRAP-132H-660M12	34	2384x 1303 x 35	500	1500	42.99	14.93	35.29	14.17
HRAP-132H-670M12	34	2384x 1303 x 35	504	1500	43.19	14.98	35.49	14.20
HRAP-132H-675M12	34	2384x 1303 x 35	508	1500	43.39	15.03	35.69	14.23

8.6 Low irradiance electrical parameters

Model Name	Weight [KG]	Dimensions [length x width x height]	Pmax (with tolerance) [W]	System voltage [V]	Voc (with tolerance) [V]	Isc (with tolerance) [A]	VPmax [V]	IPmax [A]
HRAP-120H-365M6	19.5	1755x 1038 x 35	71.54 ± 3%	1500	38.58 ± 3%	2.25 ± 3%	32.96	2.26
HRAP-120H-370M6	19.5	1755x 1038 x 35	72.52 ± 3%	1500	38.77 ± 3%	2.27 ± 3%	33.12	2.28
HRAP-120H-375M6	19.5	1755x 1038 x 35	73.5 ± 3%	1500	38.96 ± 3%	2.28 ± 3%	33.28	2.29
HRAP-144H-435M6	23.5	2094x 1038 x 35	85.26 ± 3%	1500	46.34 ± 3%	2.25 ± 3%	39.58	2.24
HRAP-144H-440M6	23.5	2094x 1038 x 35	86.24 ± 3%	1500	46.53 ± 3%	2.26 ± 3%	39.74	2.25
HRAP-144H-445M6	23.5	2094x 1038 x 35	87.22 ± 3%	1500	46.71 ± 3%	2.28 ± 3%	39.91	2.27
HRAP-144H-450M6	23.5	2094x 1038 x 35	88.22 ± 3%	1500	46.90 ± 3%	2.29 ± 3%	40.07	2.28
HRAP-144H-455M6	23.5	2094x 1038 x 35	89.22 ± 3%	1500	47.10 ± 3%	2.31 ± 3%	40.09	2.29
HRAP-144H-460M6	23.5	2094x 1038 x 35	90.22 ± 3%	1500	47.30 ± 3%	2.34 ± 3%	40.12	2.30
HRAP-108H-400M10	21.5	1724x 1134 x 30	78.4 ± 3%	1500	34.54 ± 3%	2.75 ± 3%	29.51	2.73
HRAP-108H-405M10	21.5	1724x 1134 x 30	79.38 ± 3%	1500	34.78 ± 3%	2.76 ± 3%	29.71	2.74
HRAP-108H-410M10	21.5	1724x 1134 x 30	80.36 ± 3%	1500	35.01 ± 3%	2.77 ± 3%	29.91	2.75
HRAP-120H-435M10	25	1909x 1134 x 35	85.26 ± 3%	1500	38.35 ± 3%	2.66 ± 3%	32.76	2.70
HRAP-120H-440M10	25	1909x 1134 x 35	86.24 ± 3%	1500	38.49 ± 3%	2.68 ± 3%	32.88	2.72
HRAP-120H-445M10	25	1909x 1134 x 35	87.22 ± 3%	1500	38.63 ± 3%	2.70 ± 3%	33.00	2.74
HRAP-120H-450M10	25	1909x 1134 x 35	88.2 ± 3%	1500	38.77 ± 3%	2.72 ± 3%	33.12	2.76
HRAP-120H-455M10	25	1909x 1134 x 35	89.18 ± 3%	1500	38.91 ± 3%	2.74 ± 3%	33.24	2.78
HRAP-132H-480M10	26.3	2094x 1134 x 35	94.08 ± 3%	1500	42.36 ± 3%	2.73 ± 3%	36.19	2.67
HRAP-132H-485M10	26.3	2094x 1134 x 35	95.06 ± 3%	1500	42.48 ± 3%	2.74 ± 3%	36.29	2.69
HRAP-132H-490M10	26.3	2094x 1134 x 35	96.04 ± 3%	1500	42.61 ± 3%	2.75 ± 3%	36.4	2.70
HRAP-132H-495M10	26.3	2094x 1134 x 35	97.02 ± 3%	1500	42.73 ± 3%	2.77 ± 3%	36.50	2.72
HRAP-132H-500M10	26.3	2094x 1134 x 35	98 ± 3%	1500	42.85 ± 3%	2.78 ± 3%	36.60	2.73
HRAP-132H-505M10	26.3	2094x 1134 x 35	98.98 ± 3%	1500	42.97 ± 3%	2.8 ± 3%	36.71	2.75
HRAP-144H-525M10	29	2279x 1134 x 35	102.9 ± 3%	1500	46.20 ± 3%	2.73 ± 3%	39.46	2.67
HRAP-144H-530M10	29	2279x 1134 x 35	103.88 ± 3%	1500	46.34 ± 3%	2.74 ± 3%	39.58	2.69
HRAP-144H-535M10	29	2279x 1134 x 35	104.86 ± 3%	1500	46.48 ± 3%	2.75 ± 3%	39.71	2.70
HRAP-144H-540M10	29	2279x 1134 x 35	105.84 ± 3%	1500	46.62 ± 3%	2.77 ± 3%	39.83	2.72
HRAP-144H-545M10	29	2279x 1134 x 35	106.82 ± 3%	1500	46.76 ± 3%	2.78 ± 3%	39.94	2.73
HRAP-144H-550M10	29	2279x 1134 x 35	107.8 ± 3%	1500	46.90 ± 3%	2.8 ± 3%	40.06	2.75
HRAP-156H-570M10	31	2474x 1134 x 35	111.72 ± 3%	1500	50.02 ± 3%	2.68 ± 3%	42.73	2.72
HRAP-156H-575M10	31	2474x 1134 x 35	112.7 ± 3%	1500	50.16 ± 3%	2.69 ± 3%	42.85	2.73
HRAP-156H-580M10	31	2474x 1134 x 35	113.68 ± 3%	1500	50.30 ± 3%	2.71 ± 3%	42.97	2.75
HRAP-156H-585M10	31	2474x 1134 x 35	114.66 ± 3%	1500	50.44 ± 3%	2.72 ± 3%	43.09	2.76
HRAP-156H-590M10	31	2474x 1134 x 35	115.64 ± 3%	1500	50.59 ± 3%	2.74 ± 3%	43.21	2.77
HRAP-120E-390M12	21.3	1761x 1098 x 35	76.44 ± 3%	1500	38.35 ± 3%	2.42 ± 3%	32.76	2.42
HRAP-120E-395M12	21.3	1761x 1098 x 35	77.42 ± 3%	1500	38.54 ± 3%	2.44 ± 3%	32.92	2.44
HRAP-120E-400M12	21.3	1761x 1098 x 35	78.4 ± 3%	1500	38.72 ± 3%	2.45 ± 3%	33.08	2.45
HRAP-120E-405M12	21.3	1761x 1098 x 35	79.38 ± 3%	1500	38.91 ± 3%	2.46 ± 3%	33.24	2.47
HRAP-150E-480M12	26.3	2185x 1098 x 35	94.08 ± 3%	1500	47.75 ± 3%	2.39 ± 3%	40.79	2.39
HRAP-150E-485M12	26.3	2185x 1098 x 35	95.06 ± 3%	1500	48.03 ± 3%	2.41 ± 3%	41.03	2.41
HRAP-150E-490M12	26.3	2185x 1098 x 35	96.04 ± 3%	1500	48.22 ± 3%	2.42 ± 3%	41.19	2.42
HRAP-150E-495M12	26.3	2185x 1098 x 35	97.02 ± 3%	1500	48.41 ± 3%	2.44 ± 3%	41.35	2.44
HRAP-150E-500M12	26.3	2185x 1098 x 35	98.00 ± 3%	1500	48.59 ± 3%	2.45 ± 3%	41.51	2.45

HRAP-150E-505M12	26.3	2185x 1098 x 35	98.98 ± 3%	1500	48.78 ± 3%	2.47 ± 3%	41.67	2.46
HRAP-110H-530M12	28.6	2384x 1098 x 35	103.88 ± 3%	1500	34.87 ± 3%	3.66 ± 3%	29.79	3.61
HRAP-110H-535M12	28.6	2384x 1098 x 35	104.86 ± 3%	1500	35.06 ± 3%	3.67 ± 3%	29.95	3.62
HRAP-110H-540M12	28.6	2384x 1098 x 35	105.84 ± 3%	1500	35.25 ± 3%	3.68 ± 3%	30.11	3.63
HRAP-110H-545M12	28.6	2384x 1098 x 35	106.82 ± 3%	1500	35.43 ± 3%	3.69 ± 3%	30.27	3.64
HRAP-110H-550M12	28.6	2384x 1098 x 35	107.8 ± 3%	1500	35.62 ± 3%	3.70 ± 3%	30.43	3.65
HRAP-110H-555M12	28.6	2384x 1098 x 35	108.78 ± 3%	1500	35.81 ± 3%	3.71 ± 3%	30.59	3.66
HRAP-110H-560M12	28.6	2384x 1098 x 35	109.78 ± 3%	1500	36.01 ± 3%	3.73 ± 3%	30.72	3.69
HRAP-120H-585M12	30.9	2172x 1303 x 35	114.66 ± 3%	1500	38.44 ± 3%	3.67 ± 3%	32.84	3.63
HRAP-120H-590M12	30.9	2172x 1303 x 35	115.64 ± 3%	1500	38.63 ± 3%	3.68 ± 3%	33.00	3.64
HRAP-120H-595M12	30.9	2172x 1303 x 35	116.62 ± 3%	1500	38.82 ± 3%	3.69 ± 3%	33.16	3.65
HRAP-120H-600M12	30.9	2172x 1303 x 35	117.6 ± 3%	1500	39.01 ± 3%	3.70 ± 3%	33.32	3.66
HRAP-120H-605M12	30.9	2172x 1303 x 35	118.58 ± 3%	1500	39.19 ± 3%	3.71 ± 3%	33.48	3.67
HRAP-120H-610M12	30.9	2172x 1303 x 35	119.68 ± 3%	1500	39.32 ± 3%	3.73 ± 3%	33.62	3.69
HRAP-132H-640M12	34	2384x 1303 x 35	125.44 ± 3%	1500	42.19 ± 3%	3.66 ± 3%	36.04	3.63
HRAP-132H-645M12	34	2384x 1303 x 35	126.42 ± 3%	1500	42.38 ± 3%	3.67 ± 3%	36.20	3.64
HRAP-132H-650M12	34	2384x 1303 x 35	127.4 ± 3%	1500	42.57 ± 3%	3.68 ± 3%	36.36	3.65
HRAP-132H-655M12	34	2384x 1303 x 35	128.38 ± 3%	1500	42.57 ± 3%	3.69 ± 3%	36.46	3.66
HRAP-132H-660M12	34	2384x 1303 x 35	129.36 ± 3%	1500	42.94 ± 3%	3.70 ± 3%	36.68	3.67
HRAP-132H-670M12	34	2384x 1303 x 35	130.36 ± 3%	1500	43.31 ± 3%	3.71 ± 3%	37.00	3.68
HRAP-132H-675M12	34	2384x 1303 x 35	131.36 ± 3%	1500	43.68 ± 3%	3.72 ± 3%	37.12	3.70

Manufacturer information:

APEX SOLAR ENERGY TECHNOLOGY(YANGZHOU)CO.,LTD

ADD:NO. 1 XINJING ROAD, TIANSHAN INDUSTRIAL CONCENTRATION ZONE,

SONGQIAO TOWN, GAOYOU CITY, JIANGSU PROVINCE ,CHINA

WEBSITE: WWW.APEX-SOLARENERGY.COM

TEL:+86 400-110-1828

EMAIL:sales@apex-solarenergy.com